

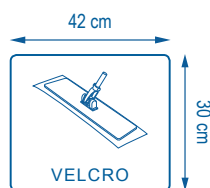

ULTIMATE DeLux

 MADE IN EUROPE
PATENT PENDING



SMART TEXTILES





SMART TEXTILES

ULTIMATE DeLux

MADE IN EUROPE
PATENT PENDING

NEW GENERATION TRIPLE ACTION MICROFIBER MOP (WASHING, DRYING, ABSORBING)

One day a buyer for a famous American fast food chain said to us: «I'd like a mop that cleans more than 100 m² in one go, absorbs half a litre of soft drink that has been spilled on the floor, doesn't fall off the trolley in the dining room among the diners, dries the floor directly after washing, doesn't require the use of "wet floor" signs, fits easily under tables and chairs, washes both parquet and tiles and degreases floors so they're not sticky».



That all?? Easy! As textile engineers, we stopped eating and sleeping and thought only about meeting this challenge... and how hungry and tired we were!

In short, we had all the elements to create an exceptional product as we knew our customer's expectations.

After a few weeks of prototyping and trials, we launched the *DeLux* mop (a nod to this famous sandwich). The first generation fulfilled all the customer's criteria but was a bit heavy and bulky. A few years later, we submitted our *ULTIMATE* patent, which enabled us to put the final touch to this project.

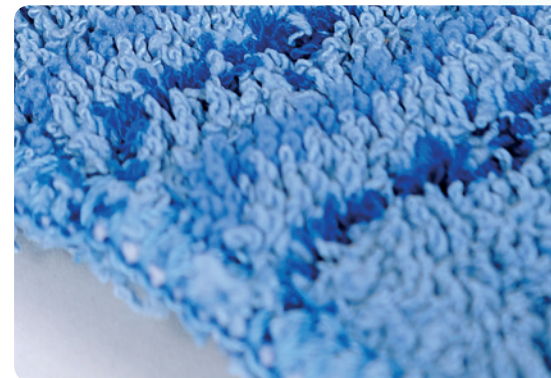

The latest addition, *ULTIMATE DeLux*, has all the advantages of *DeLux* plus the patented *ULTIMATE* technology. With more microfiber, the *ULTIMATE* technology boosts efficiency and makes it glide easily over the floor. The front of the mop, with alternating design, removes dirt while the 100 % microfiber rear holds it in. In addition to making our customer's dreams a reality, the *ULTIMATE DeLux* is now light and compact. A simple demonstration will win you over!

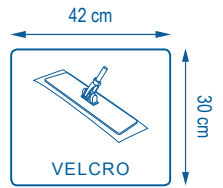

TECHNICAL SPECIFICATIONS

DECITEX 100 760

48 % microfiber
(100 % polyester)
39 % microfiber
(80 % polyester /
20 % polyamide)
8 % polyester
5 % polypropylene

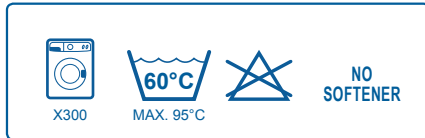

- Description:** New generation triple action microfiber mop (washing, drying, absorbing)
- Packaging:** Box of 5 bags of 2 Ultimate DeLux
- Dry weight:** 180 g
- Absorption rate (water):** 1 mop Ultimate DeLux for 1/2 L of solution
- Finish:** Technical sewing



PATENTED TECHNOLOGY

The **ULTIMATE** technology represents technical advancement in microfiber engineering to simultaneously **increase the proportion of pure microfiber** to increase absorption capacity and cleaning efficiency while **optimizing the ergonomic glide** across the floor surface.

ULTIMATE TECHNOLOGY

PROTECTED BY PATENT

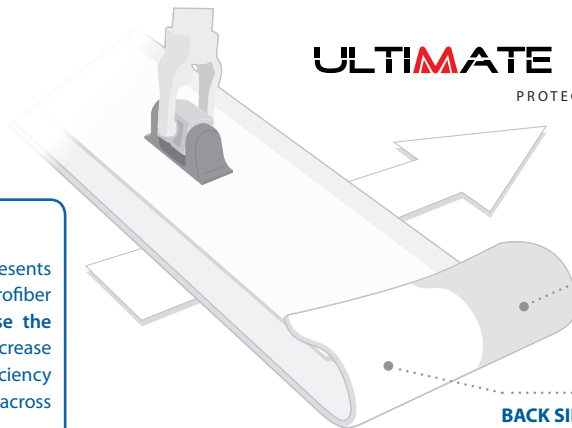

FRONT SIDE - INCREASED MECHANICAL ACTION AND GLIDE
Alternating weave of microfibers and scrubbing fibers

BACK SIDE - OPTIMIZED ADSORPTION AND SOIL REMOVAL
100% microfiber



ULTIMATE Dispomop®



ULTIMATE 3D

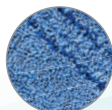

ULTIMATE M600



ULTIMATE Dx1



ULTIMATE Duo - grey



ULTIMATE Duo - white

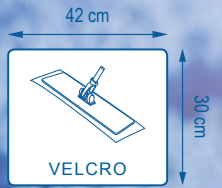

PROTOCOL



Local authorities



Hotels



Restaurants



Cafés



Cleaning companies

① Start with a dry mop

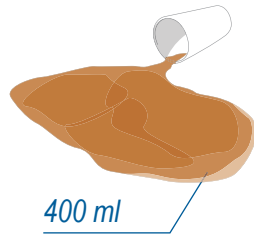
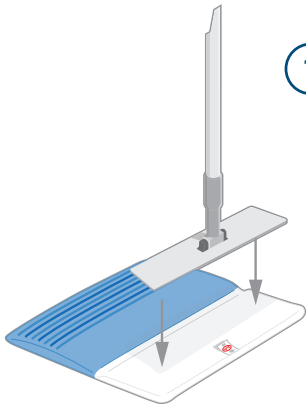

② Soak up any liquid on the floor

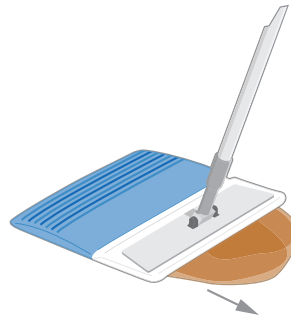

③ Fold and squeeze the mop

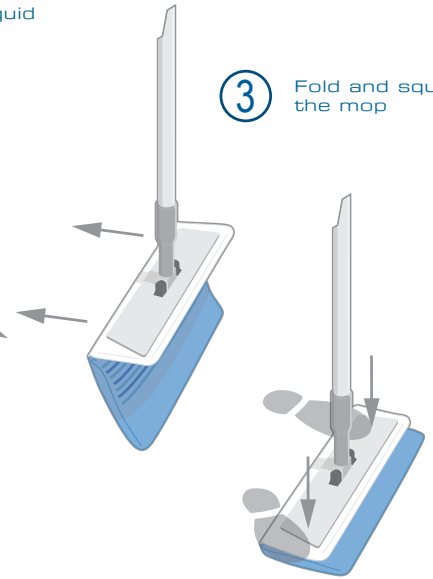

⚠ Always sweep the floor before washing.

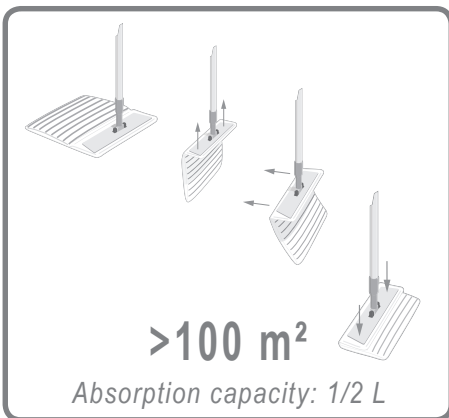

④ Dispense the solution to start cleaning the floor

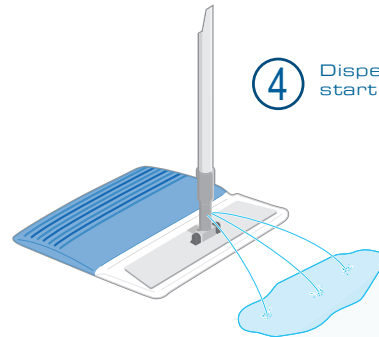

⑤ Unhook the mop

