

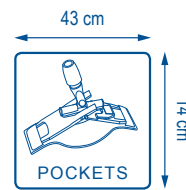

# ULTIMATE Duo - white

FABRIQUÉ EN EUROPE  
BREVET DÉPOSÉ

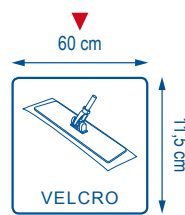
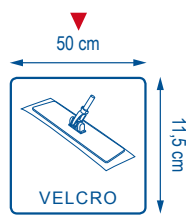
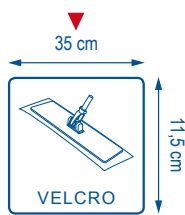

SMART TEXTILES





SMART TEXTILES

# ULTIMATE Duo - white

FABRIQUÉ EN EUROPE  
BREVET DÉPOSÉ

## MOP MICROFIBRE PREMIUM - EFFICACE MÊME SUR SOL ANTIDÉRAPANT

La sécurité d'abord, l'hygiène après... C'est bien le choix implicite que vous avez fait le jour où vous avez opté pour ce sol antidérapant dont le nettoyage est devenu un casse-tête quotidien. Vous n'êtes pas seul ! C'est rassurant mais pas suffisant et c'est pourquoi DECITEX va vous offrir la solution que vous attendiez depuis si longtemps, mais pas seulement !



Comme son nom l'indique, L'ULTIMATE Duo - white bénéficie de la technologie ULTIMATE brevetée. Grâce à ses filaments rigides et orientés pour travailler à rebrousse-poil, l'avant de L'ULTIMATE Duo - white (côté bord retourné) soulève la saleté et la retient au fond de son réseau de microfibre pour ne plus la lâcher. C'est cette partie avant qui facilite aussi la glisse sur sols antidérapants. L'arrière plus doux, composé à 100 % de microfibres s'occupera des particules plus fines.

Qui peut le plus...

L'ULTIMATE Duo - white est la mop la plus polyvalente de la gamme et son bord retourné ira chercher la saleté même le long des plinthes. Elle existe aussi en gris (ULTIMATE Duo - grey) pour le balayage électrostatique, le blanc étant plutôt dédié à l'étape de lavage par imprégnation mais ça, c'est vous qui voyez !



L'ULTIMATE Duo - white est très dense (950 g / m<sup>2</sup>) couvrant ainsi des surfaces allant de 50 à plus de 100 m<sup>2</sup> en fonction de l'encrassement. Elle est faite pour durer sur plus de 500 lavages et grâce à sa palette de quatre couleurs, vous pourrez l'affecter par zone de travail ou faciliter la redistribution logistique dans votre service.



SMART TEXTILES

# ULTIMATE Duo - white

FABRIQUÉ EN EUROPE  
BREVET DÉPOSÉ

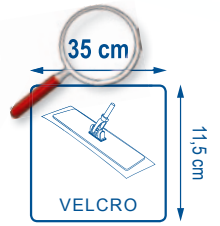

	100 837
	100 838
	100 839
	100 840

## CARACTÉRISTIQUES TECHNIQUES

80 % microfibre  
(100 % polyester)  
20 % polyester



60°C  
MAX. 95°C



PAS  
D'ADOUCCISSANT



**Description :** Mop microfibre Premium - efficace même sur sol antidérapant

**Conditionnement :** Cartons de 10 sachets de 10 Ultimate Duo - white

**Construction :** Technologie V.M.P. (velours microfibre polyester)

**Poids au m<sup>2</sup> :** 950 g

**Poids sec :** 57,5 g

**Poids essoré :** 140 g

**Imprégnation :** 3 mops pour 1/2 L de solution

**Finition :** Surjet technique

**Finesse du fil :** 0,56 dTex



### TECHNOLOGIE BREVETÉE

L'ULTIMATE est la seule technologie capable d'augmenter la proportion de microfibre pour plus d'efficacité sans affecter la glisse au sol pour plus d'ergonomie.

### TECHNOLOGIE ULTIMATE

BREVET DÉPOSÉ

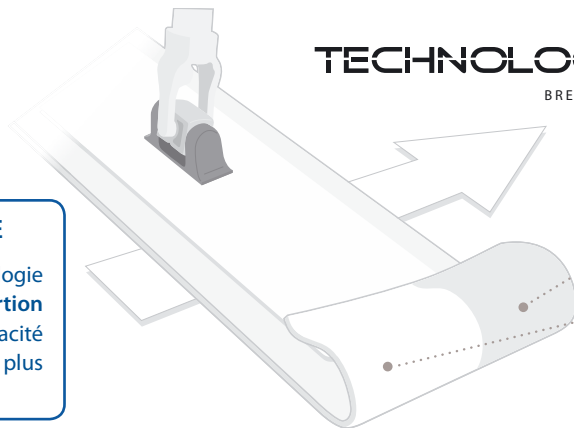

#### CÔTÉ QUI FACILITE LA GLISSE

Alternance de microfibras et fibres grattantes

#### CÔTÉ QUI DÉGRAISSE EN PROFONDEUR

100 % microfibre



ULTIMATE Dispomop®

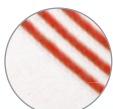

ULTIMATE 3D\*

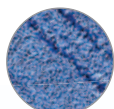

ULTIMATE M600



ULTIMATE Dx1



ULTIMATE Duo - grey



ULTIMATE Duo - white

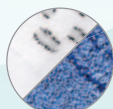

ULTIMATE DeLux



## PROTOCOLE



Services de santé



Maisons de retraite



Collectivités



Hôtels



Restaurants



Cafés

### Étape 1 Préparer le nombre nécessaire d'Ultimate Duo - white dans le bac.

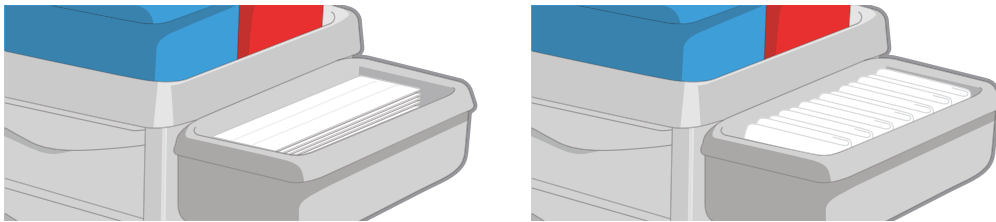

- disposition des mops à plat ou pliée -

### Étape 2 Pré-imbiber les mops en se référant au tableau ci-dessous.



1/2 L	1 L	1 L 1/2	2 L	3 L	4 L	8 L
3 mops	6 mops	9 mops	12 mops	18 mops	24 mops	48 mops

### Étape 3 Lavage des sols avec la Ultimate Duo - white.

⚠️ Précéder toujours le lavage d'un balayage.

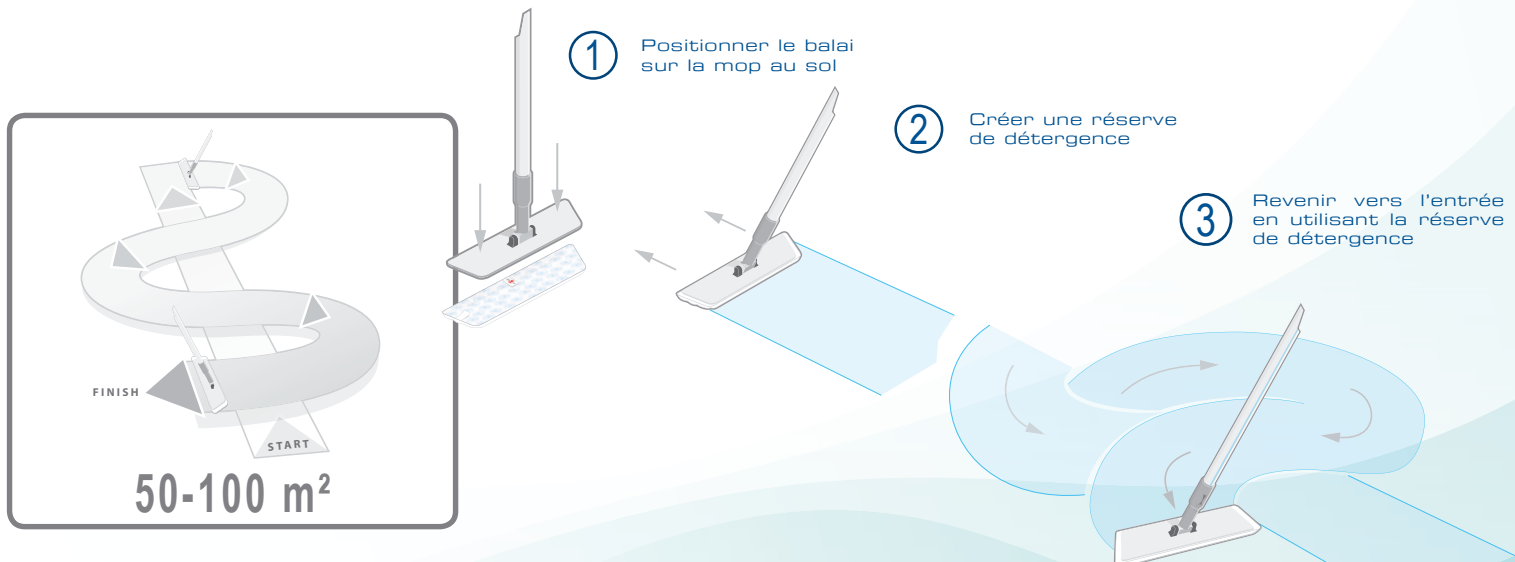





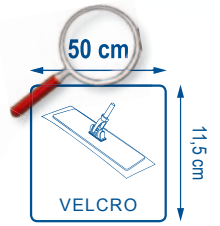

SMART TEXTILES

# ULTIMATE Duo - white

FABRIQUÉ EN EUROPE  
BREVET DÉPOSÉ



-  ..... 100 766
-  ..... 100 767
-  ..... 100 768
-  ..... 100 769

## CARACTÉRISTIQUES TECHNIQUES

80 % microfibre  
(100 % polyester)  
20 % polyester



60°C  
MAX. 95°C



PAS  
D'ADOUCCISSANT



**Description :** Mop microfibre Premium - efficace même sur sol antidérapant

**Conditionnement :** Cartons de 10 sachets de 10 Ultimate Duo - white

**Construction :** Technologie V.M.P. (velours microfibre polyester)

**Poids au m<sup>2</sup> :** 950 g

**Poids sec :** 82 g

**Poids essoré :** 200 g

**Imprégnation :** 2 mops pour 1/2 L de solution

**Finition :** Surjet technique

**Finesse du fil :** 0,56 dTex



### TECHNOLOGIE BREVETÉE

L'ULTIMATE est la seule technologie capable d'augmenter la proportion de microfibre pour plus d'efficacité sans affecter la glisse au sol pour plus d'ergonomie.

### TECHNOLOGIE ULTIMATE

BREVET DÉPOSÉ

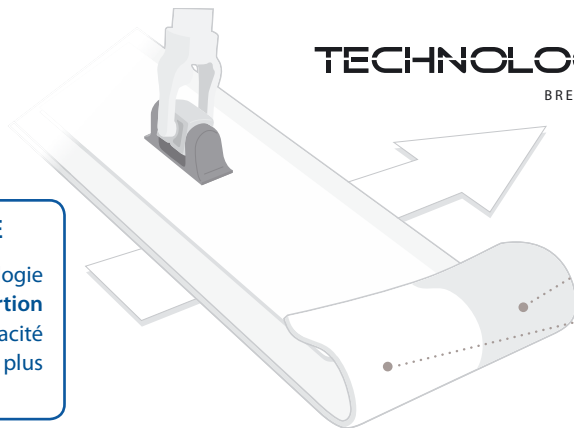

#### CÔTÉ QUI FACILITE LA GLISSE

Alternance de microfibras et fibres grattantes

#### CÔTÉ QUI DÉGRAISSE EN PROFONDEUR

100 % microfibre



ULTIMATE Dispomop®



ULTIMATE 3D®

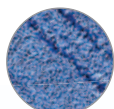

ULTIMATE M600



ULTIMATE Dx1



ULTIMATE Duo - grey



ULTIMATE Duo - white

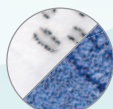

ULTIMATE DeLux

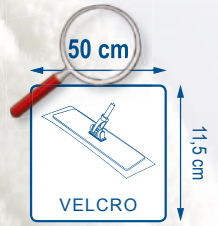

## PROTOCOLE



Services de santé



Maisons de retraite



Collectivités



Hôtels



Restaurants



Cafés

### Étape 1 Préparer le nombre nécessaire d'Ultimate Duo - white dans le bac.

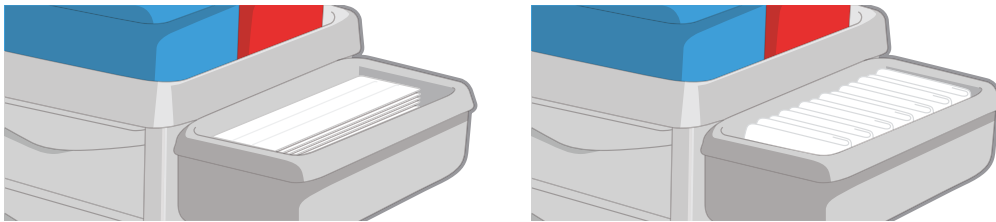

- disposition des mops à plat ou pliée -

### Étape 2 Pré-imbiber les mops en se référant au tableau ci-dessous.



1/2 L	1 L	1 L 1/2	2 L	3 L	4 L	8 L
2 mops	4 mops	6 mops	8 mops	12 mops	16 mops	32 mops

### Étape 3 Lavage des sols avec la Ultimate Duo - white.

⚠️ Précéder toujours le lavage d'un balayage.

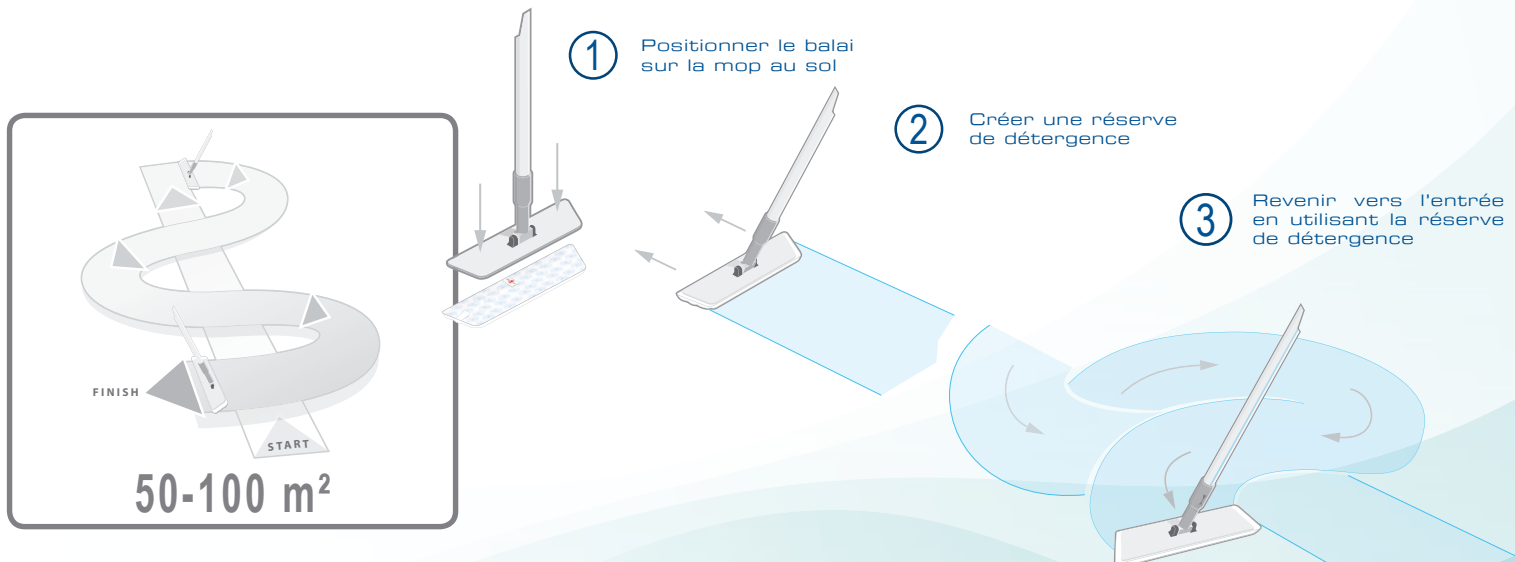

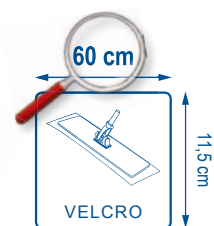

	100 841
	100 842
	100 843
	100 844

## CARACTÉRISTIQUES TECHNIQUES

80 % microfibre  
(100 % polyester)  
20 % polyester

**PAS D'ADOUCCISSANT**



<b>Description :</b>	Mop microfibre Premium - efficace même sur sol antidérapant
<b>Conditionnement :</b>	Cartons de 10 sachets de 10 Ultimate Duo - white
<b>Construction :</b>	Technologie V.M.P. (velours microfibre polyester)
<b>Poids au m<sup>2</sup> :</b>	950 g
<b>Poids sec :</b>	98,5 g
<b>Poids essoré :</b>	240 g
<b>Imprégnation :</b>	1 mop pour 1/2 L de solution
<b>Finition :</b>	Surjet technique
<b>Finesse du fil :</b>	0,56 dTex



### TECHNOLOGIE BREVETÉE

L'ULTIMATE est la seule technologie capable d'augmenter la proportion de microfibre pour plus d'efficacité sans affecter la glisse au sol pour plus d'ergonomie.

### TECHNOLOGIE ULTIMATE

BREVET DÉPOSÉ

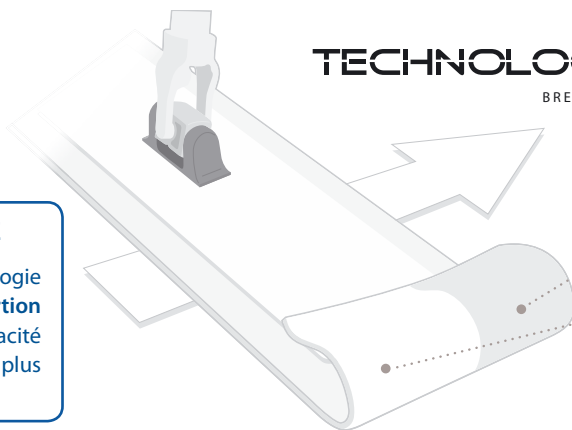

**CÔTÉ QUI FACILITE LA GLISSE**  
Alternance de microfibrés et fibres grattantes

**CÔTÉ QUI DÉGRAISSE EN PROFONDEUR**  
100 % microfibre

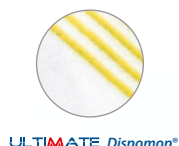

ULTIMATE Dispomop®



ULTIMATE 3D®

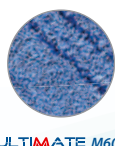

ULTIMATE M600



ULTIMATE Dx1



ULTIMATE Duo - grey



ULTIMATE Duo - white



ULTIMATE DeLux



## PROTOCOLE



Services de santé



Maisons de retraite



Collectivités



Hôtels



Restaurants



Cafés

### Étape 1 Préparer le nombre nécessaire d'Ultimate Duo - white dans le bac.

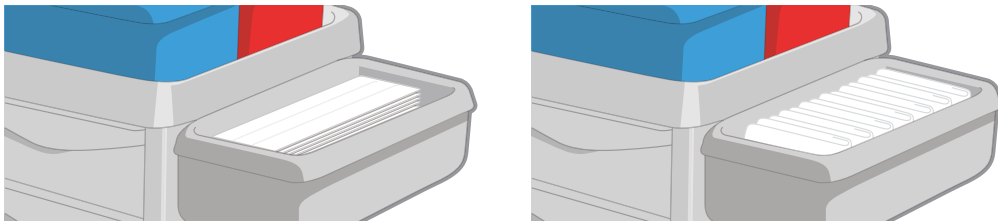

- disposition des mops à plat ou pliée -

### Étape 2 Pré-imbiber les mops en se référant au tableau ci-dessous.



1/2 L	1 L	1 L 1/2	2 L	3 L	4 L	8 L
1 mops	2 mops	3 mops	4 mops	6 mops	8 mops	16 mops

### Étape 3 Lavage des sols avec la Ultimate Duo - white.

⚠️ Précéder toujours le lavage d'un balayage.

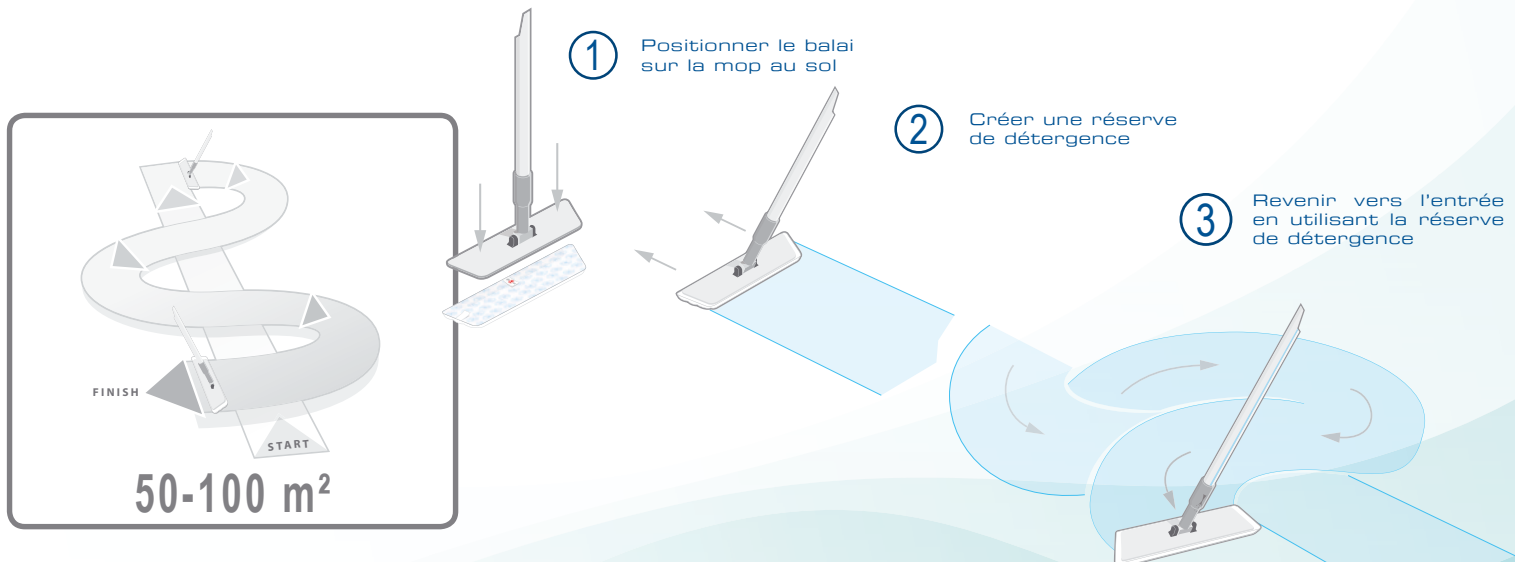







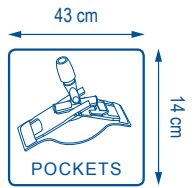

SMART TEXTILES

# ULTIMATE Duo - white

FABRIQUÉ EN EUROPE  
BREVET DÉPOSÉ



-  ..... 100 847
-  ..... 100 848
-  ..... 100 849
-  ..... 100 850

## CARACTÉRISTIQUES TECHNIQUES

80 % microfibre  
(100 % polyester)  
20 % polyester



PAS  
D'ADOUCISSANT



**Description :** Mop microfibre Premium - efficace même sur sol antidérapant

**Conditionnement :** Cartons de 10 sachets de 10 Ultimate Duo - white

**Construction :** Technologie V.M.P. (velours microfibre polyester)

**Poids au m<sup>2</sup> :** 950 g

**Poids sec :** 106 g

**Poids essoré :** 235 g

**Imprégnation :** 2 mops pour 1/2 L de solution

**Finition :** Surjet technique

**Finesse du fil :** 0,56 dTex



### TECHNOLOGIE BREVETÉE

L'ULTIMATE est la seule technologie capable d'augmenter la proportion de microfibre pour plus d'efficacité sans affecter la glisse au sol pour plus d'ergonomie.

### TECHNOLOGIE ULTIMATE

BREVET DÉPOSÉ

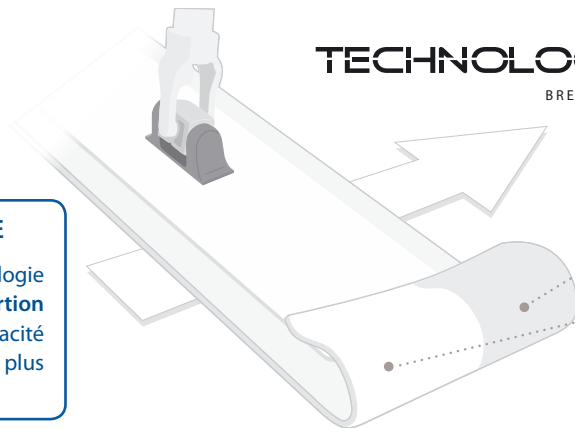

**CÔTÉ QUI FACILITE LA GLISSE**  
Alternance de microfibrilles et fibres grattantes

**CÔTÉ QUI DÉGRAISSE EN PROFONDEUR**  
100 % microfibre



ULTIMATE Dispomop®



ULTIMATE 3D®

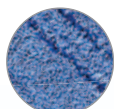

ULTIMATE M600



ULTIMATE Dx1



ULTIMATE Duo - grey



ULTIMATE Duo - white

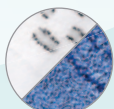

ULTIMATE DeLux

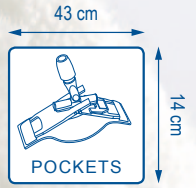

## PROTOCOLE



Services de santé



Maisons de retraite



Collectivités



Hôtels



Restaurants



Cafés

### Étape 1 Préparer le nombre nécessaire d'Ultimate Duo - white dans le bac.

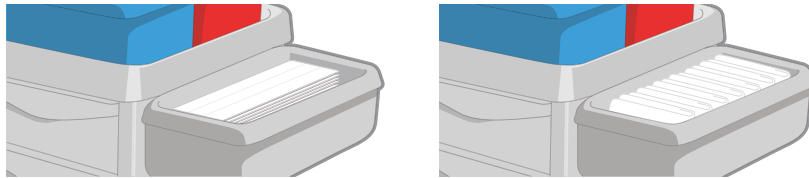

- disposition des mops à plat ou pliée -

### Étape 2 Pré-imbiber les mops en se référant au tableau ci-dessous.



1/2 L	1 L	1 L 1/2	2 L	3 L	4 L	8 L
2 mops	4 mops	6 mops	8 mops	12 mops	16 mops	32 mops

### Étape 3 Lavage des sols avec la Ultimate Duo - white.

Précéder toujours le lavage d'un balayage.

